

# GYMSTICK™

## PRO20.0 CROSSTRAINER USER MANUAL



IMPORTANT: Read all instructions carefully before using this product. Retain this owner's manual for future reference. The specifications of this product may vary from this photo, subject to change without notice.



GYMSTICK.COM

Thank you for choosing the Gymstick PRO20.0 Crosstrainer. We take great pride in producing this quality product and hope it will provide many hours of effective exercise to make you feel better, look better and enjoy life to its fullest.

**TABLE OF CONTENT**

1.	SAFETY INSTRUCTIONS .....	3
2.	EXPLODED DRAWING.....	4
3.	PARTS LIST.....	6
4.	ASSEMBLY INSTRUCTION.....	9
5.	COMPUTER OPERATION INSTRUCTIONS.....	17
6.	MAINTENANCE.....	23
7.	TROUBLESHOOTING.....	23
8.	IMPLIED WARRANTY.....	24



**NOTIFICATION!**

READ AND FOLLOW THE SAFETY INSTRUCTIONS. FAILURE TO FOLLOW THESE INSTRUCTIONS CAN RESULT IN SERIOUS INJURY.

**Basic precautions should always be followed, including the following safety instructions when using this equipment: Read all instructions before using this equipment.**

1. Keep children and pets away from the machine at all times. DO NOT leave unattended children in the same room with the machine.
2. Handicapped or disabled persons should not use the machine without the presence of a qualified health professional or physician.
3. If the user experiences dizziness, nausea, chest pain, or any other abnormal symptoms, STOP the workout at once. CONSULT A PHYSICIAN IMMEDIATELY.
4. Before beginning training, remove all within a radius of 2 meters from the machine. DO NOT place any sharp objects around the device.
5. Position the machine on a clear, level surface away from water and moisture. Place mat under the unit to help keep the machine stable and to protect the floor.
6. Use the machine only for its intended use as described in this manual. DO NOT use any other accessories not recommended by the manufacturer.
7. Assemble the machine exactly as the descriptions in the instruction manual.
8. Check all bolts and other connections before using the machine for the first time and ensure that the trainer is in the safe condition.
9. Hold a routine inspection of the equipment. Pay special attention to components which are the most susceptible to wear off, i.e. connecting points and wheels. The defective components should be replaced immediately. The safety level of this equipment can only be maintained by doing so.
10. NEVER operate the machine if it is not functioning properly.
11. This machine can be used for only one person's training at a time.
12. Do not use abrasive cleaning articles to clean the machine. Remove drops of sweat from the machine immediately after finishing training.
13. Always wear appropriate workout clothing when exercising. Running or aerobic shoes are also required.
14. Before exercising, always do warm-up and stretching first.
15. Maximum user weight: **180 kg**







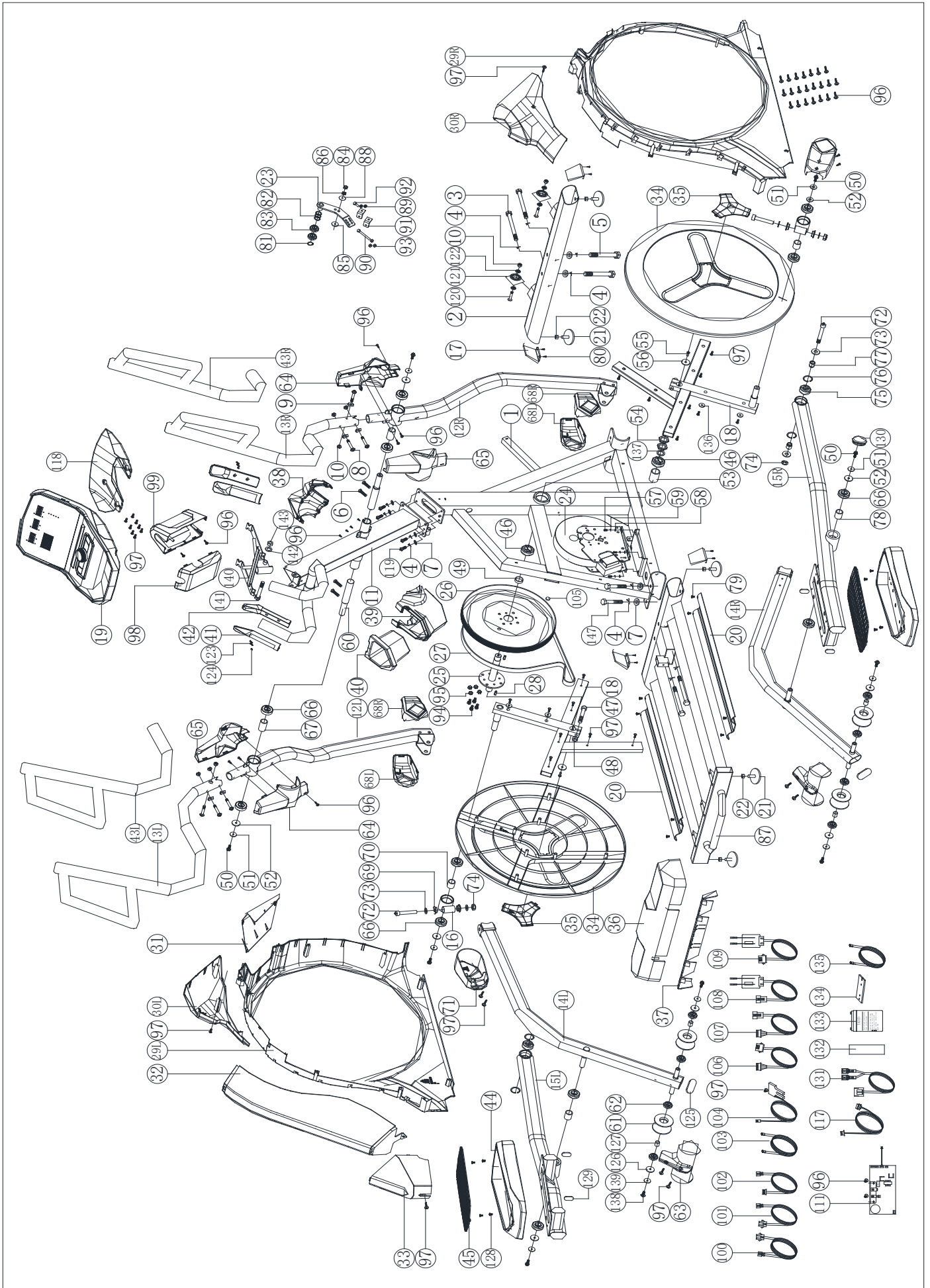

## **WARNING!**

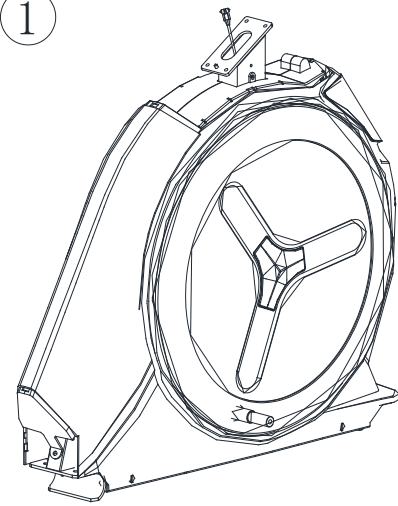
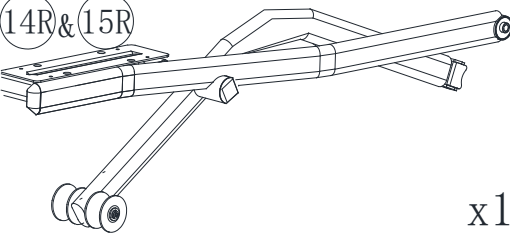
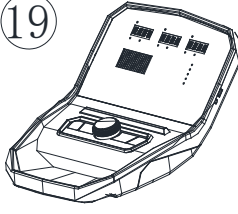
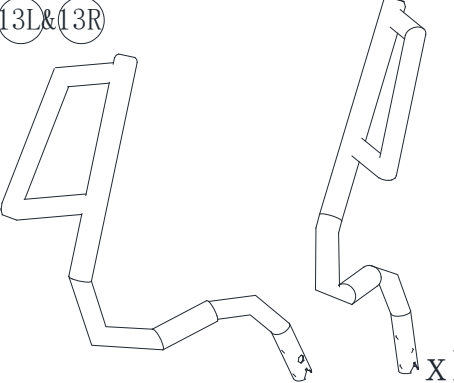
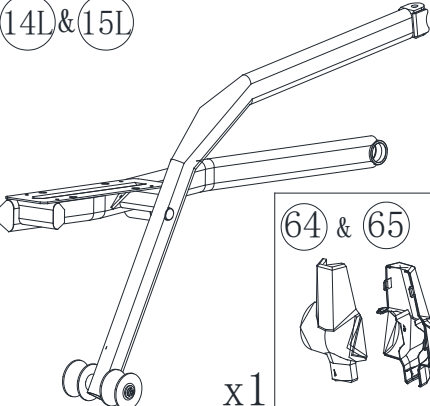
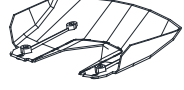
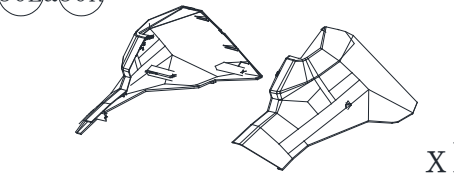
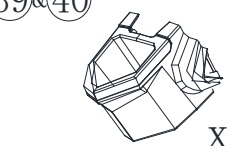
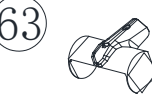
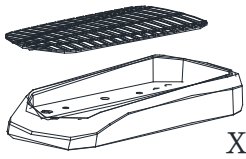
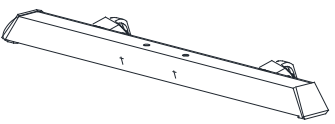
BEFORE BEGINNING THIS OR ANY EXERCISE PROGRAM, CONSULT YOUR PHYSICIAN FIRST. THIS IS ESPECIALLY IMPORTANT FOR INDIVIDUALS OVER THE AGE OF 35 OR PERSONS WITH PRE-EXISTING HEALTH PROBLEMS.

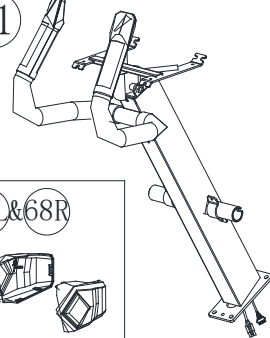
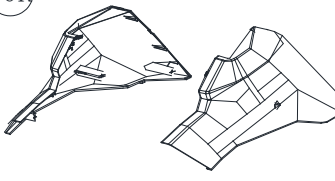
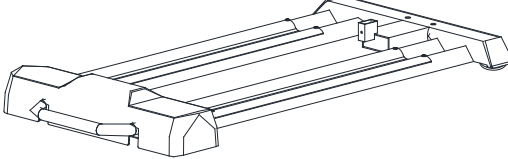

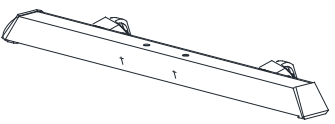
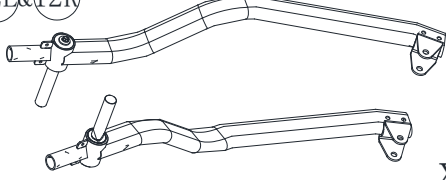
PART CHECK LIST

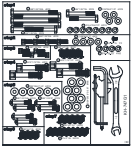
 <p>1</p> <p>x1</p>	 <p>14R &amp; 15R</p> <p>x1</p>	 <p>19</p> <p>x1</p>	
 <p>13L &amp; 13R</p> <p>x1</p>	 <p>14L &amp; 15L</p> <p>x1</p>	 <p>118</p> <p>x1</p>	
 <p>30L &amp; 30R</p> <p>x1</p>	 <p>39 &amp; 40</p> <p>x1</p>	 <p>63</p> <p>x2</p>	 <p>44 &amp; 45</p> <p>x2</p>
 <p>2</p> <p>x1</p>	 <p>98 &amp; 99</p> <p>x1</p>	 <p>38</p> <p>x1</p>	 <p>11</p> <p>x1</p>
 <p>87</p> <p>x1</p>	 <p>87</p> <p>x1</p>	 <p>33</p> <p>x1</p>	
 <p>12L &amp; 12R</p> <p>x1</p>	 <p>12L &amp; 12R</p> <p>x1</p>	 <p>71</p> <p>x2</p>	 <p>71</p> <p>x1</p>

Part no.	Description	Specification	Q'ty
1	Main frame		1
2	Front stabilizer		1
3	Bolt	M8*1.25*120L	4
4	Spring washer	D15.4xD8.2x2T	12
5	Bolt	M8*1.25*70L	2
6	Bolt	M8*1.25*20L	4
7	Flat washer	D16*D8.5*1.2T	8
8	Allen bolt	M8*1.25*50L	6
9	Curved washer	D22xD8.5x1.5T	6
10	Anti-loose nut	M8*1.25*8T	8
11	Handlebar post		1
12L	Left movable support welding set		1
12R	Right movable support welding set		1
13L	Left moving handlebar		1
13R	Right moving handlebar		1
14L	Left pedal supporting tube		1
14R	Right pedal supporting tube		1
15L	Left pedal bracket welding set		1
15R	Right pedal bracket welding set		1
16	Universal joint		2
17	Foot tube cap		2
18	Crank welding set		2
19	Computer		1
20	Slide beam		2
21	Adjusting round wheel		6
22	Hex nut	M10*1.5*8T	6
23	Idle wheel fixing plate		1
24	Self-generator		1
25	Crank axle welding set		1
26	Belt wheel		1
27	Belt	520 PJ8	1
28	C flat key	8*7*20L	2
29L	Left chain cover		1
29R	Right chain cover		1
30L	Left front chain cover		1
30R	Right front chain cover		1
31	Front modified cover		1
32	Upper modified cover		1
33	Rear modified cover		1
34	Round disc		2
35	Side cover		2
36	Rear stabilizer cover		1
37	Rear stabilizer inside cover		1
38	Water bottle holder (front)		1
39	Water bottle holder (rear)		1
40	Water bottle		1
41	Hand pulse cable upper cover		2
42	Hand pulse cable lower cover		2
43L	Dip foam(left)		1
43R	Dip foam(right)		1
44	Pedals		2
45	Pedal pads		2

Part no.	Description	Specification	Q'ty
46	Bearing	#6205,2RS,SKF	2
47	Bolt	M10*1.5*65L	2
48	Hex nut	M10*1.5*8T	4
49	Spacer ring	D29.5*D25.2*9T	1
50	Bolt	M8*1.25*20L	6
51	Flat washer	D25xD8.5x2T	6
52	Buffer	D27*D8.2*2.5T	6
53	Sleeve	D30*D25.2*45L	1
54	Fixing nut	M25*1.5*32*6T	2
55	Bolt	M6*1.0*10L	2
56	Flat washer	D28*D6.5*2T	2
57	Screw	M6*1.0*15L	4
58	Flat washer	D13*D6.5*1.0T	4
59	Spring washer	D10.5*D6.1*1.3T	4
60	Swing axle	D25*180.5L	2
61	Roller wheel	D70*43	4
62	Bearing	6002 2RS,SKF	8
63	Roller wheel cover	162*136.2*87	2
64	Handlebar cover(front)	240.5*127.8*59	2
65	Handlebar cover (rear)	240.5*127.8*50	2
66	Bearing	#60042RS,SKF	12
67	Sleeve(二)	D25.4*D20.2*44L	2
68L	Front foot cover (left)	152.3*91.1*46.7	2
68R	Front foot cover (right)	152.3*91.1*60	2
69	Spacer bushing	D29*D12.1*9T	4
70	screened pipe	D25.4*D20.2*26L	2
71	Front pedal axle cover	182.4*95.7*67.6	2
72	Bolt	M12*1.75*70L	4
73	Flat washer	D24*D13.5*D2.5T	8
74	Anti-loose nut	M12*1.75*12T	4
75	Bearing	#2203-2RS	2
76	C ring	S-40(1.8T) D40	2
77	Space bushing	D19*D17*D12*20T	4
78	bushing	D25.4*D20.2*31L	2
79	Bolt	M6*1*15L	8
80	Screw	ST4.2*15L	8
81	C ring	S-17(1T)	1
82	Waved washer	D17*D22*0.3T	3
83	Bearing	6203-2RS ,SKF	2
84	Anti-loose nut	M8*1.25*8T	1
85	Flat washer	D28*D8.5*3T	1
86	Hex nut	M8*1.25*6T	1
87	Sliding beam welding set		1
88	Plastic flat washer	D50*D10*1.0T	1
89	Anti-loose nut	M6x1.0x6T	2
90	Bolt	M6*75L	1
91	Fixing sheet	20*27*4T	2
92	Bolt	M6x1.0x15L	2
93	Bolt	M6*1*5T	3
94	Bolt	M8x1.25x20L	4
95	Hex nut	M8*1.25*8T	4
96	Screw	ST4.2*15L	49

Part no.	Description	Specification	Q'ty
97	Bolt	M5*0.8*12L	38
98	Computer bracket(front)		1
99	Computer bracket(right)		1
100	Upper computer cable	300L	1
101	Middle computer cable	900L	1
102	Lower computer cable	650L	1
103	Connecting cable	1000L	1
104	sensor cable	500L	1
105	Round magnet		1
106	Upper cable for quick button (1)	400L	1
107	Upper cable for quick button (2)	400L	1
108	Lower cable for quick button (1)	850L	1
109	Lower cable for quick button (2)	850L	1
111	control board		1
117	Power cable	620L	1
118	Computer back cover		1
119	Bolt	M8*1.25*25L	4
120	Bolt	M8*1.25*40L	2
121	Roller wheel		2
122	Spacer bushing	D22.2*D8.2*7T	4
123	Screw	M3*0.5*30L	4
124	Screw	M3*0.5*12L	2
125	End cap		2
126	Buffer	D21*D8.2*2.5T	4
127	Spacer ring	D19*D15.2*25.5L	4
128	Bolt	M6*1*15L	8
129	End cap		4
130	Round cap		2
131	Battery connecting cable		1
132	Buffer	25*2T*80	2
133	Chargeable battery		1
134	Fixing plate(1)		1
135	Connecting cable(2)	1000L	1
136	Flat washer	D15*D5.2*1.0T	4
137	Flat washer	D34*D26*2T	1
138	Bolt	M8*1.25*20L	4
139	Flat washer	D18*D8.5*1.2T	4
140	Computer fixed base welding set		1
141	Bolt	M10*1.5*75L	1
142	Flat washer	D20*D11*2T	1
143	Hex nut	M10*1.5*10T	1
144	Pin	D6*26.5*7.7	2
145	Screw	ST4*1.41*12L	3
147	Bolt	M8*1.25*55L	2

## STEP 1.

1. Assemble the front stabilizer (2) to the main frame (1) with:
  - bolt (3)
  - flat washer (7)
  - spring washer (4)
  - bolt (5)
2. Assemble the sliding beam welding set (87) to the main frame (1) with:
  - bolt (147)
  - bolt (3)
  - flat washer (7)
  - spring washer (4)

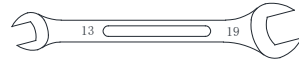



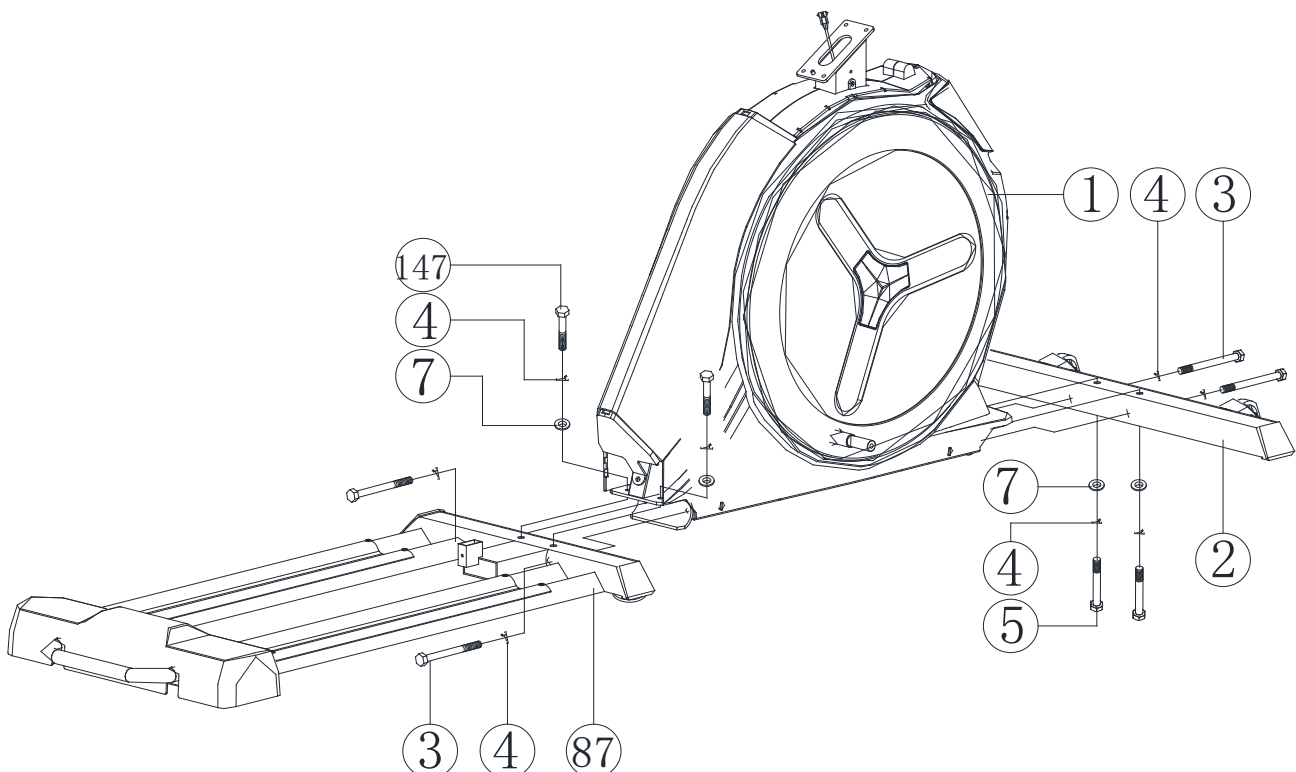

③	M8*1.25*120L	x4
⑤	M8*1.25*70L	x2
④	D15.4*D8.2*2T	x8
⑦	D18xD8.5x1.2T	x4
⑭⑦	M8*1.25*55L	x2

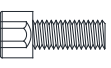

## STEP 2.

1. Fix the middle computer cable (101) to the lower computer cable (102)
2. Assemble the handlebar post (11) to the main frame (1) with:
  - bolt (119)
  - spring washer (4)
  - flat washer (7)
3. Use bolt (97) to the fix the rear modified cover (33).



119		M8*1.25*25L	x4
4		D15.4*D8.2*2T	x4
7		D18xD8.5x1.2T	x4
97		M5*0.8*12L	x1

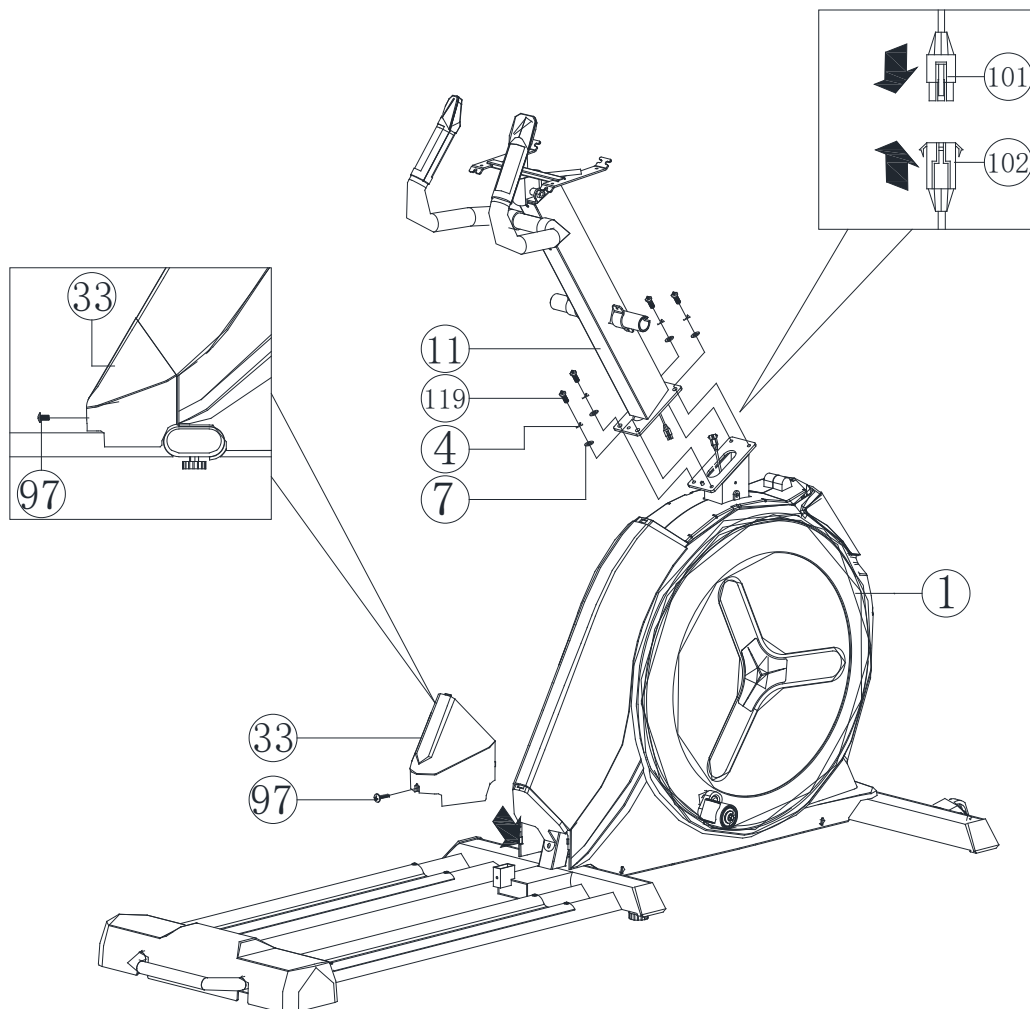

## STEP 3.

1. Assemble the left and right movable support welding set (12L and 12R) to the handlebar post (11) with bolt (6). As shown in figure below.

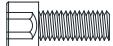

6		M8*1.25*20L	x4
---	--	-------------	----

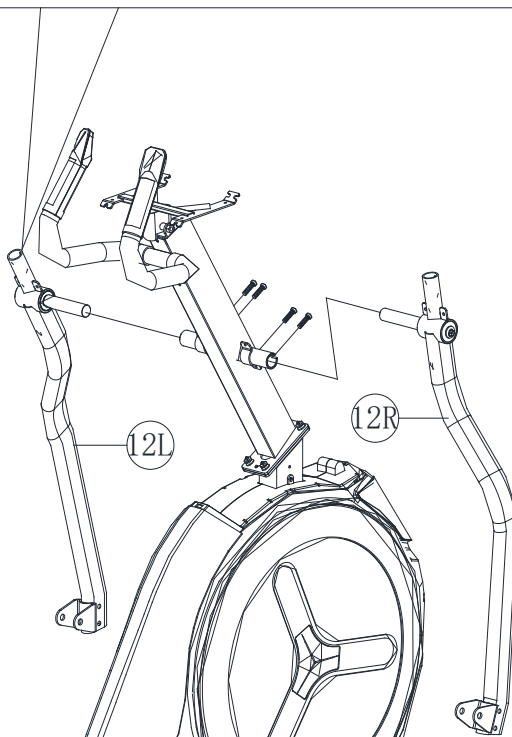
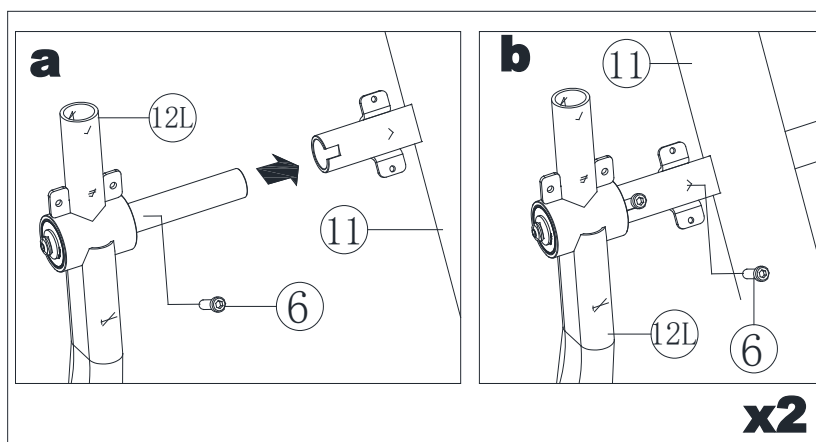

# step3

## STEP 4.

1. Assemble the right pedal supporting tube (14R) to the main frame (1) as shown in fig 4-1 with:
  - bolt (72), flat washer (73), anti-loose nut (74)
2. Assemble the right movable support welding set (12R) to the right pedal bracket welding set (15R) with:
  - bolt (72), flat washer (73), anti-loose nut (74), as shown in figure 4-2
3. Assemble the pedals (44) to the right pedal bracket welding set (15R) with:
  - cross bolt (128), as shown in figure 4-3 (a)
4. Assemble the pedal pads (45) to pedals (44) as shown in figure 4-3 (b).

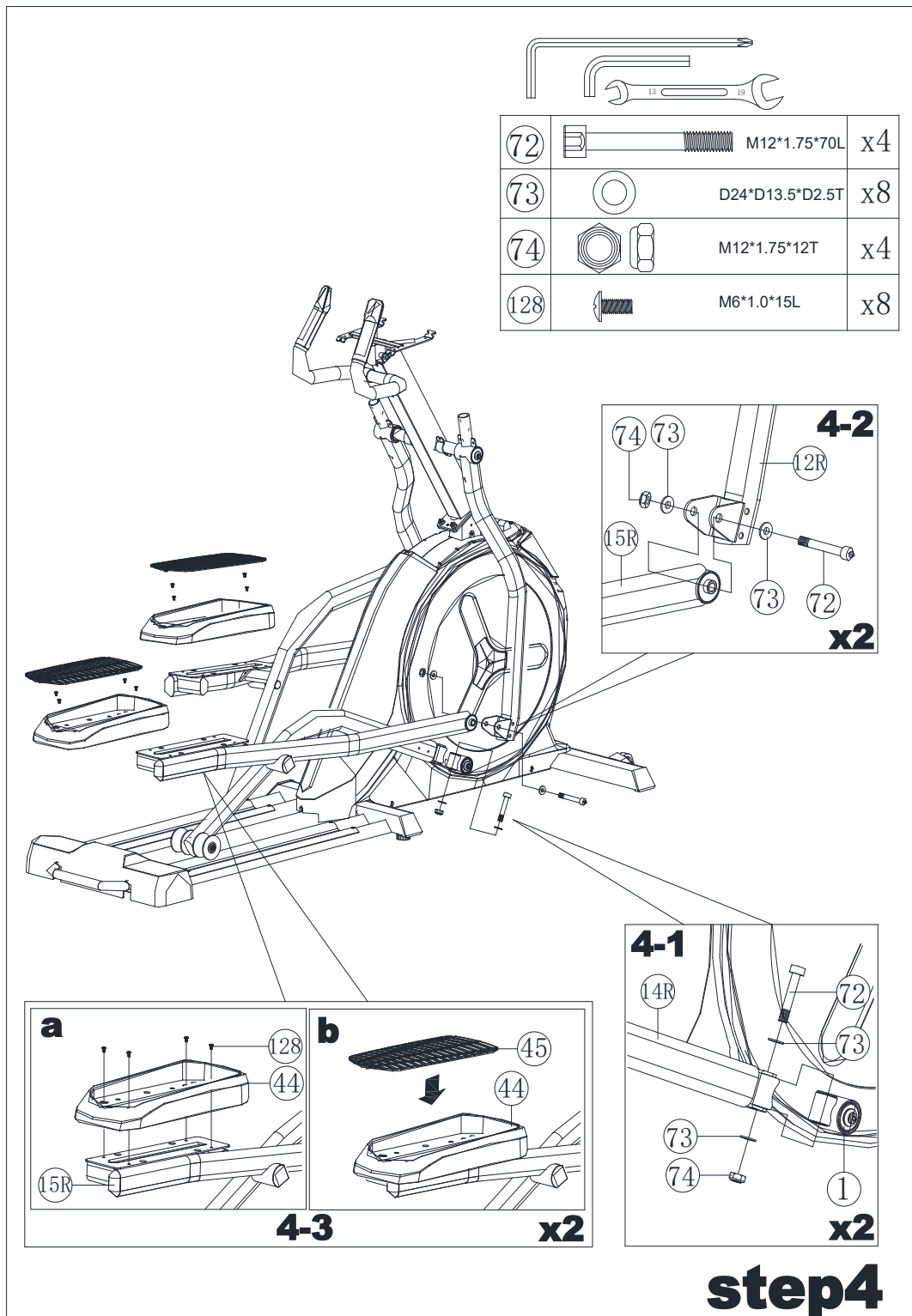

STEP 5.

1. Assemble the right moving handlebar (13R) to the right movable support welding set (12R), with:
  - bolt (8), curved washer (9), anti-loose nut (10) as shown in figure 5-1
2. Assemble the left moving handlebar (13L) to the left movable support welding set (12L), with:
  - bolt (8), curved washer (9), anti-loose nut (10) as shown in figure 5-2

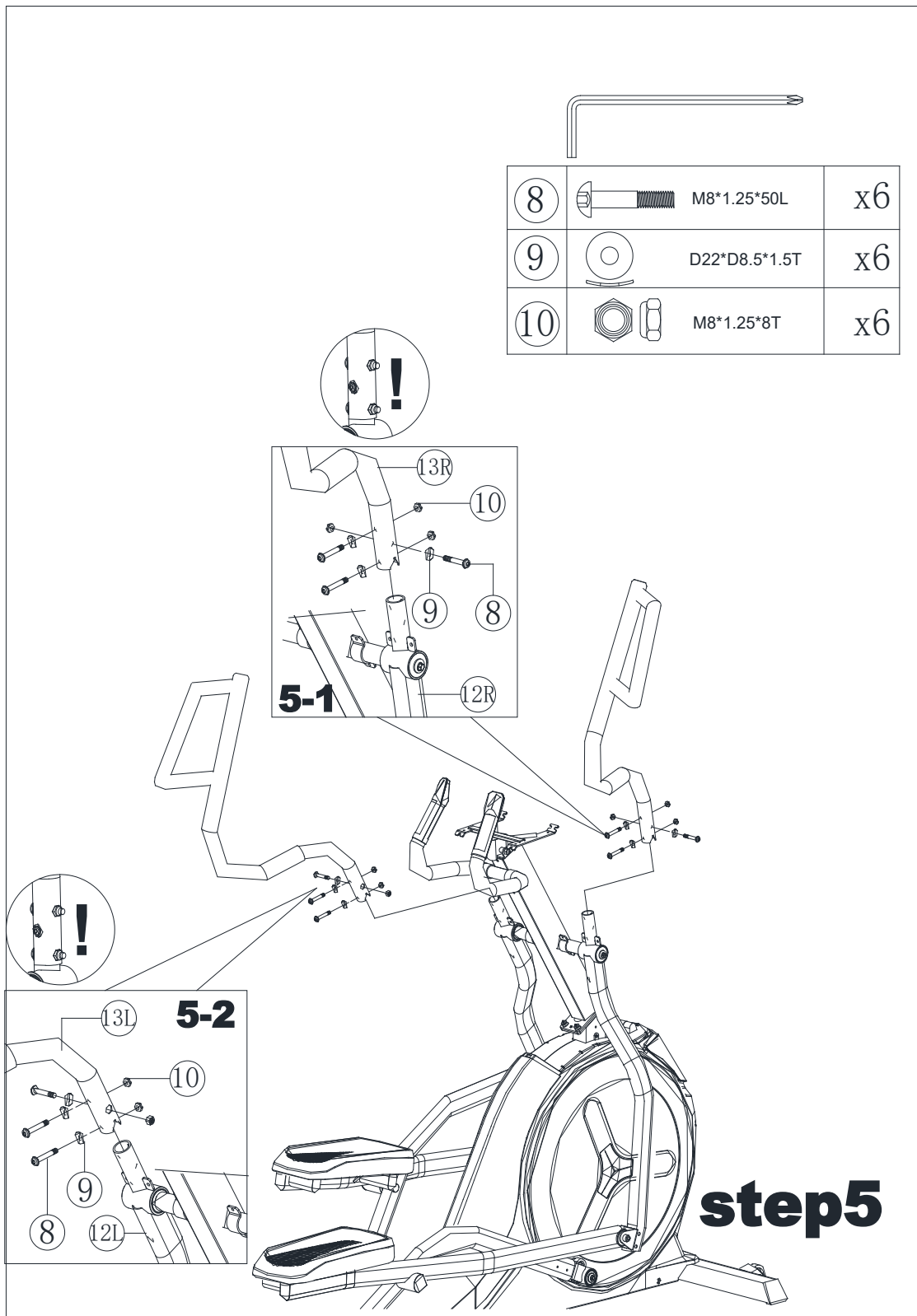

STEP 6.

1. Assemble the computer (19), fix the upper computer (100) to the middle computer (101), figure 6-1.
  - Upper cable for quick button (1) (106) to the lower cable for quick button (1) (108).
  - Upper cable for quick button (2) (107) to the lower cable for quick button (2) (109).
2. Assemble the computer (19) to the handlebar post (11) using bolt (97) as shown in figure 6-2.
3. Assemble the computer back cover (118) to the handlebar post (11) with bolt (97), figure 6-3.

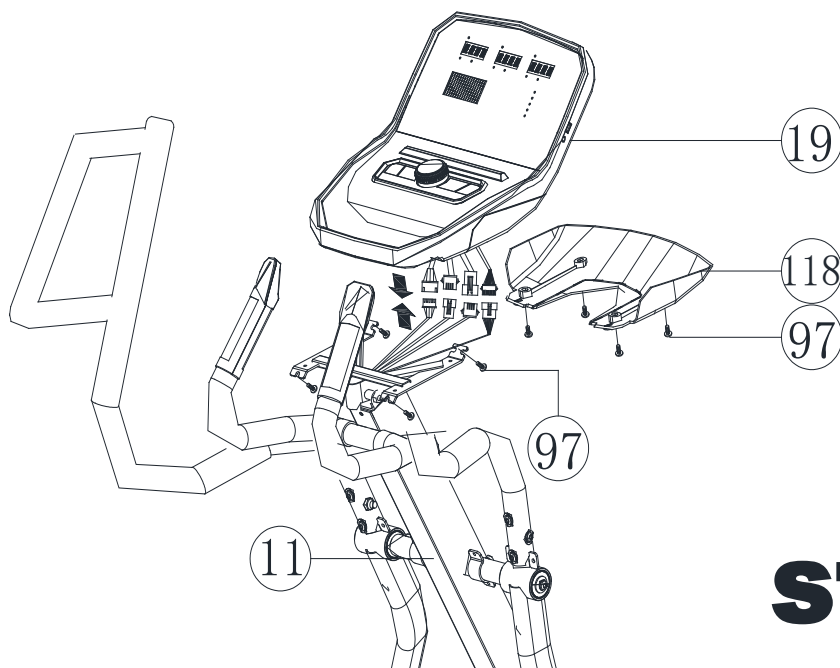
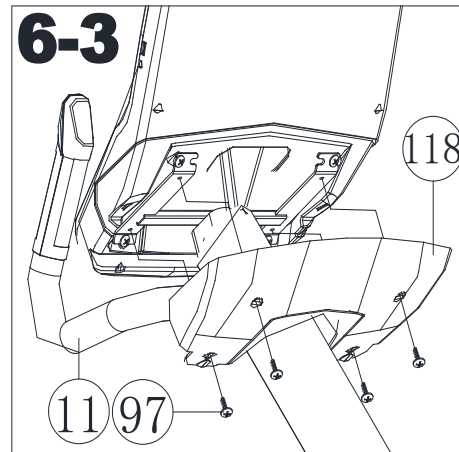
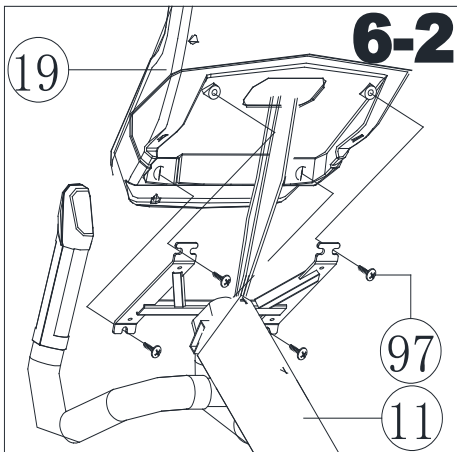
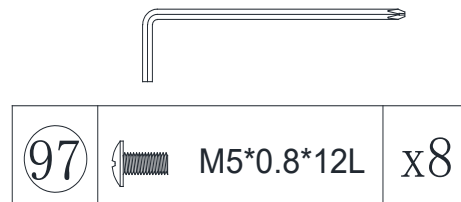
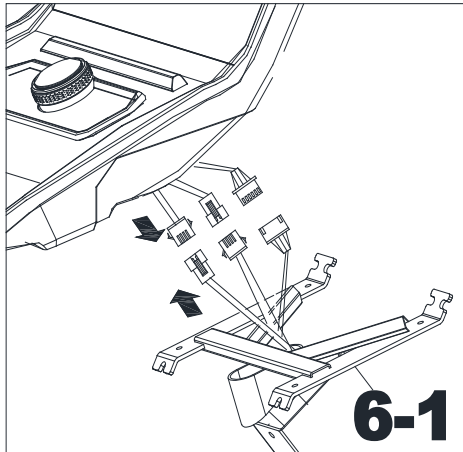

**step6**

STEP 7.

1. Fix the computer bracket (front) (98) and the computer bracket (right) (99) to the handlebar post (11), with screw (96) as shown in figure 7-1.
2. Fix the water bottle holder (front) (39) and the water bottle holder (right) (38) to the handlebar post (11), with screw (96) as shown in figure 7-2.
3. Fix the handlebar cover (front) (64) to the handlebar cover rear (65), with screw (96), figure 7-3.
4. Assemble the front chain cover (30L&30R) for the main frame (1), with screw (96) and bolt (97), as shown in figure 7-4.
5. Fix the front foot cover left (68L) to the front cover right (68R), with screw (96), figure 7-5.
6. Assemble the roller wheel cover (63) with 2 pcs bolt (97), figure 7-6.
7. Fix the 2 pcs axle cover (71), with bolt (97), as shown in figure 7-7.

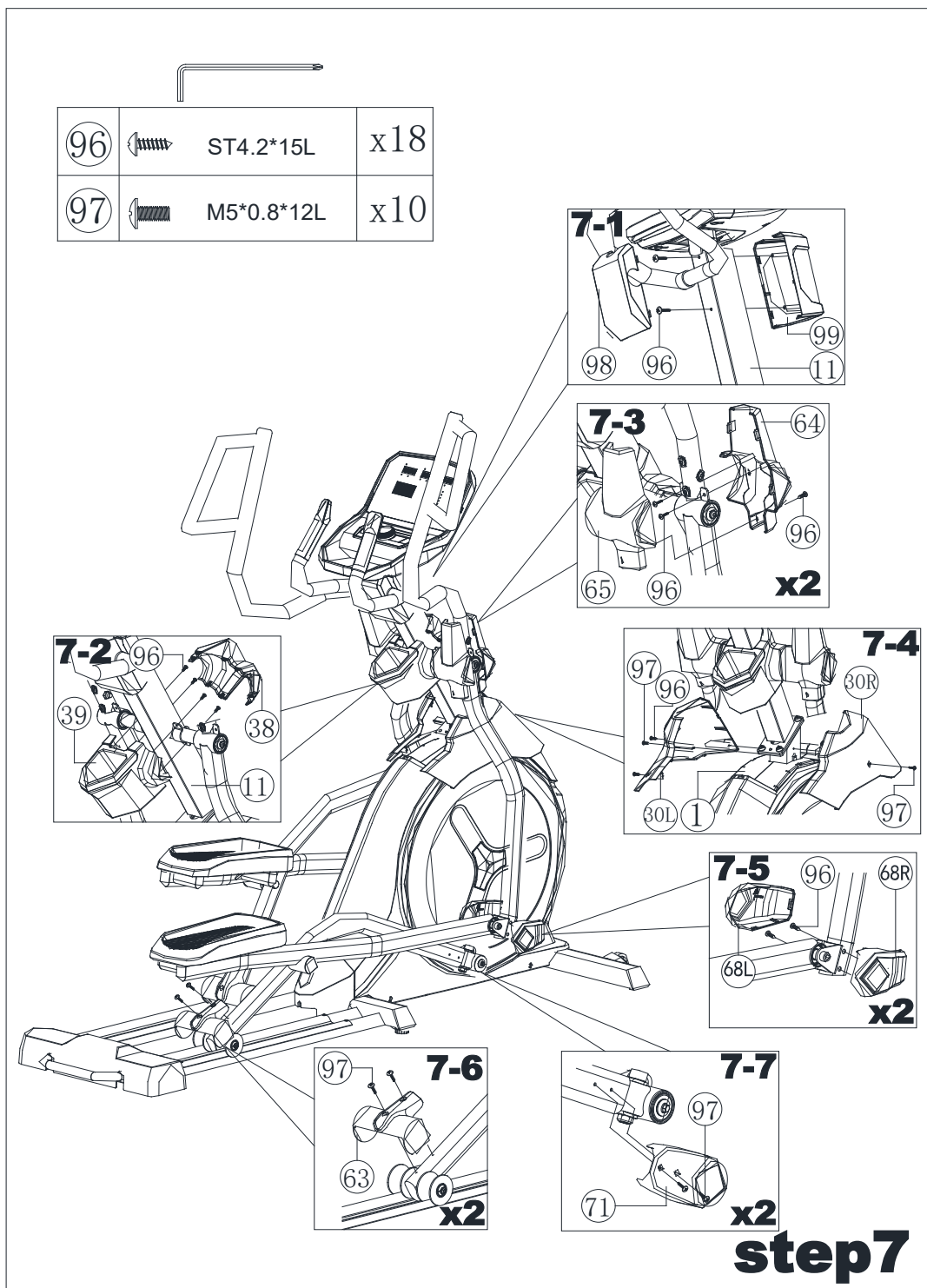

## STEP 8.

1. Insert the power cord.
2. Adjust the ground wheels at the same height.

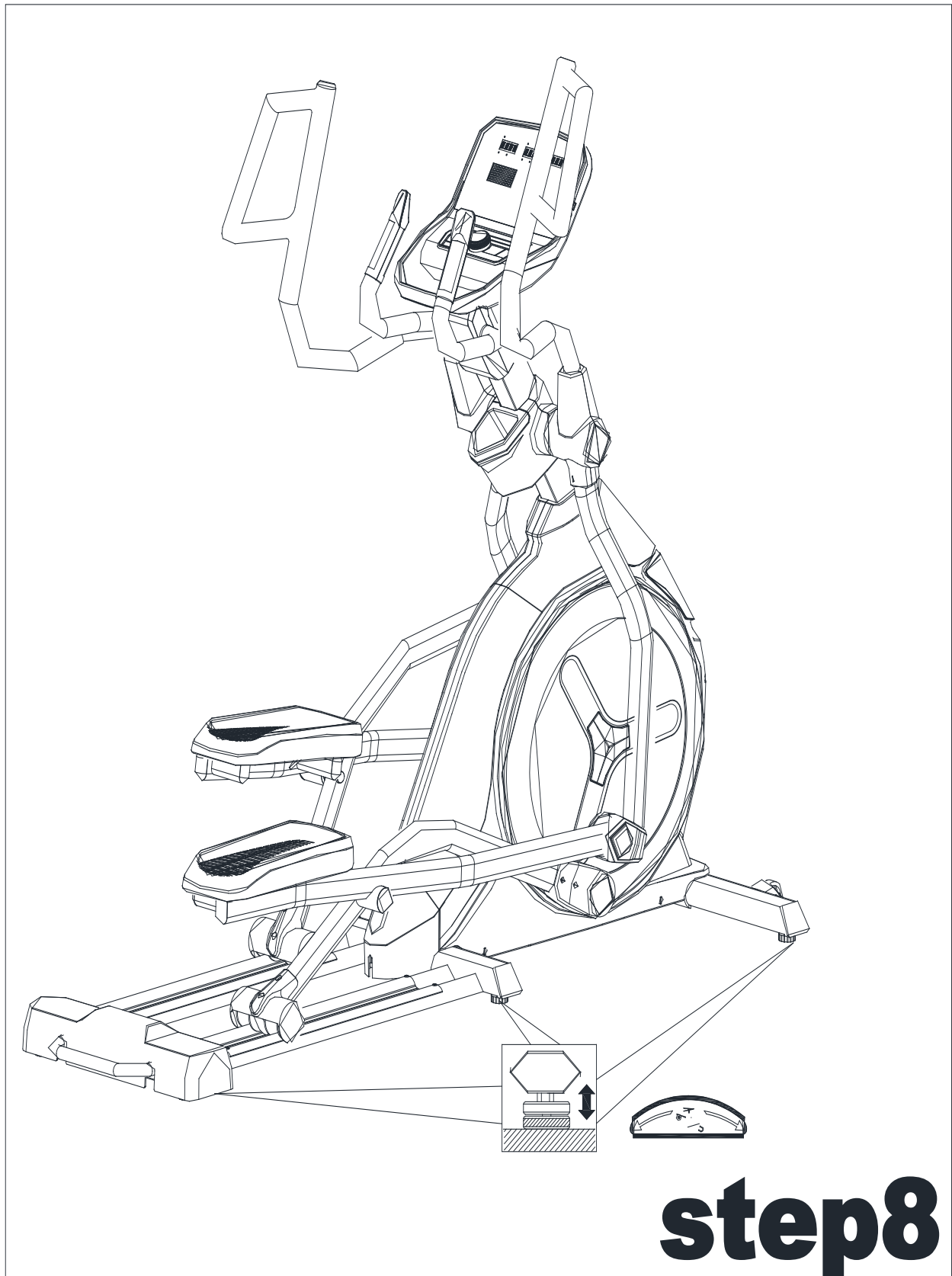

## DISPLAY FUNCTIONS

ITEMS	DESCRIPTION
TIME	Setting range: 0:00~99:00 (±1 minute) Display range: 0:00~99:59
DISTANCE	Setting range: 0.00~99.0 (±1) Display range: 0.00~99.99
CALORIES	Setting range: 0~9990 (±10) Display range: 0~9999
PULSE	Setting range: 0~30~230 (±1) Display range: 0~230
WATTS	Display range: 0~999
SPEED	Display current working speed, max 99.9
RPM	Display current RPM Display range : 0~999

## BUTTON FUNCTIONS

ITEMS	DESCRIPTION
+	Setting or increase the training resistance.
-	Setting or decrease training resistance.
ROTARY BUTTON	To confirm all setting.
STAR/STOP	To start or stop workout.
RESET	In setting mode or in selection mode, press to go back to initial training mode. If keep pressing this button 2s, computer will restart.
RECOVERY	To test heart rate recovery status.
BODY FAT	To test body fat % when press the BODY FAT button in standby mode.

OPERATING MANUAL

Power on

1. When powering on the device, the LED-display will display all segments, such as wheel diameter, KM or ML, Eurasian gauge. (Image 1 & 2)

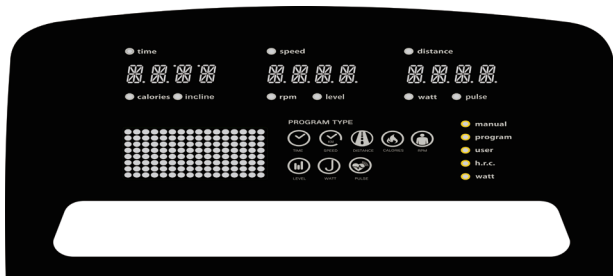

Image 1. Image 2.

2. Enter into user selection mode, setting user's private file U1-U4 (image 3), GENDER (image 4), AGE (image 5), HEIGHT (image 6), WEIGHT (image 7). After setting the information, device will enter into function selection mode: MANUAL, PROGRAM, USER PROGRAM, H.R.C, WATT.



Image 3. Image 4.



Image 5. Image 6.



Image 7.

Power off

If without RPM input for 4 minutes, LED-display will be closed and the computer will be in power off -mode. If RPM is detected again, the computer will wake up.

MANUAL FUNCTION

By turning buttons “+” or “-”, user may set up TIME > DISTANCE > CALORIES > PULSE (image 8 - 10). Press START/STOP without settings to start a workout, and in working period the user can adjust the RESISTANCE LEVEL. Press START/STOP again and the computer will enter into break mode, press button “RESET” to leave this mode.



Image 8.



Image 9.



Image 10.

PROGRAM FUNCTION

In this mode, there are 12 programs (P1~P12) for the user to select (image 11). When the user chooses a PROGRAM, by turning buttons “+” or “-”, can be set the TIME (image 12). When finished setting press “START/STOP” to start workout (in break mode the user can choose to adjust the “TIME” value). In START status, user can adjust RESISTANCE level. During workout, press “START/STOP” and the computer will enter into break mode, press “RESET” leave this mode.



Image 11.



Image 12.

PROGRAM FUNCTION

All the different programs are shown below (P1-P12).

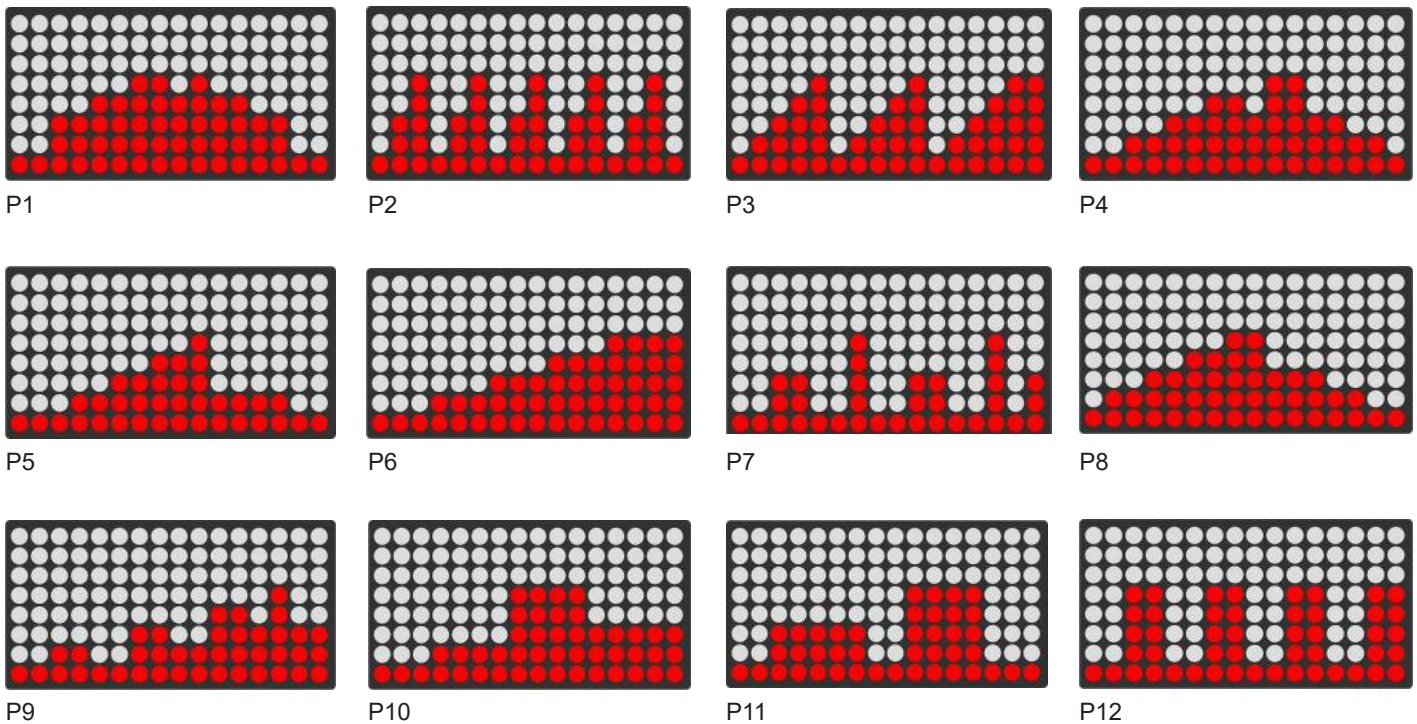

USER PROGRAM FUNCTION

By turning buttons “+” or “-”, the user can set PROGRAM, then press MODE/ENTER to confirm the setting value of RESISTANCE (image 13). If the user wants to stop the setting, keep pressing MODE/ENTER button for 2 seconds, LED-display will show last value set. While pressing MODE/ENTER button for 2 seconds, the user can set “TIME” (image14), if no value is set, press “START” to enter into working mode. In START mode user can adjust the resistance. During the workout press “START” to enter into break mode, then press button “RESET” leave this mode.



Image 13.



Image 14.

**H.R.C FUNCTION**

In H.R.C mode, the LED screen will show heart rate percentage 55%, 75%, 90% and TARGET. User may select one of the heart rate percentages by turning “+” or “-” button (image 15). TARGET preset value is 100, user can also set the pulse value by themselves. By pressing the rotary button TIME can be set (image 16). If there is no need to set TIME, press “START/ STOP “, device will start the workout according to the H.R.C function and show the current pulse value. If pulse is not detected, the LED-display will show as seen in image 17. During the workout press “START” enter into break mode, then press “RESET” to leave this mode.



Image 15.



Image 16.



Image 17.

**WATT FUNCTION**

The preset watt value is 120 (image 18). By turning “+” or “-” button, the WATT value can be set (setting range is 10-350). When done setting, press the rotary button to set TIME (image 19), if there is no need to set the TIME value, press “START/STOP”, resistance value will adjust automatically according to the set target WATT value. During the workout press “START/STOP” to enter into break mode, then press button “RESET” to leave this mode.



Image 18.



Image 19.

RECOVERY FUNCTION

1. If there is no detected pulse input press “RECOVERY” button.
2. If there is a detected pulse input, press button to enter “RECOVERY” mode; time countdown from 00:60 to 00:00 (image 20). Screen will display your heart rate recovery status F1-F6 (image 21). F1 is the best and F6 is the worst. User may keep exercising to improve their heart rate recovery status.
3. Press the RECOVERY button to leave this test mode.



Image 20.



Image 21.

BODY FAT FUNCTION

1. Press “BODY FAT” button to start testing your body fat (image 22 - image 24). At this time the user should grab the hand grips correctly, computer will display the test value.
2. If any of the following situations occur, there will be an indication showing on display.
  - “E-1” (image 25) - User did not put their thumb properly on the conductor. Please try again.
  - “E-4” - BODY FAT advice has exceeded the setting range (5%~50%).
3. After the testing has finished, display will show both BODY FAT % and BMI (image 26, image 27). During BODY FAT testing mode, press BODY FAT button to cancel the test and go back to continue the previous exercise.



Image 22.



Image 23.



Image 24.



Image 25.



Image 26.



Image 27.

## CLEANING

The machine can be cleaned with a soft cloth and mild detergent. Do not use abrasives or solvents on plastic parts. Please wipe your perspiration off after each use. Be careful not get excessive moisture on the computer display panel as this might cause an electrical hazard or electronics to fail.

Please keep the machine, especially the computer console, out of direct sunlight to prevent screen damage. Please inspect all assembly bolts and moving parts on the machine for proper tightness every week.

## STORAGE

Store the crosstrainer in a clean and dry environment away from children.

## TROUBLESHOOTING

PROBLEM	SOLUTION
The elliptical trainer wobbles when in use.	Turn the stabilizers to level the elliptical trainer.
There is no display on the computer console.	<ol style="list-style-type: none"> <li>1. Remove the computer console and verify the wires that come from the computer console are properly connected to the wires that come from the front post.</li> <li>2. Check if the battery is correctly positioned and that the wires are in proper contact with the battery.</li> </ol>
There is no heart rate reading or heart rate reading or is erratic / inconsistent.	<ol style="list-style-type: none"> <li>1. Make sure that the wire connections for the hand pulse sensors are secure.</li> <li>2. To ensure the pulse readout is more precise, please always hold on to the handlebar grip sensors with two hands instead of just with one hand only when you try to test your heart rate figures.</li> <li>3. Gripping the hand pulse sensors too tight. Try to maintain moderate pressure while holding onto the hand pulse sensors.</li> </ol>
The elliptical trainer makes a squeaking noise when in use.	The bolts may be loose on the elliptical trainer, please inspect the bolts and tighten the loose bolts.

The importer of this product assures that this device is manufactured with high quality materials.

The prerequisite for the implied warranty is the proper setup in accordance with the operating instructions. Improper use and /or incorrect transportation can void the warranty.

The implied warranty for wear parts is valid for 1 year and for frame 5 years, beginning from the date of purchase. For eventual defects please contact the dealer of this product within the guarantee period.

The warranty applies to the following parts (as far as included in the scope of delivery): frame, electronic devices, wheels, foot straps and pedals.

**The guarantee does not cover:**

- Damage effected by outer force
- Intervention by unauthorized parties
- Incorrect handling of the product
- Non-compliance of the operating instructions

Note: Wear parts and expendable parts are also not covered.

The device is intended for professional use.

Manufactured for:  
Gymstick International Oy  
Ratavartijankatu 11  
15170 Lahti, FINLAND



Devices marked with this symbol must be disposed of separately from your household waste, as they contain valuable materials which can be recycled. Proper disposal protects the environment and human health. Your local authority or retailer can provide information on the matter.

